

---

## DEVELOPMENT OF A MANUALLY OPERATED DOUGH DICING MACHINE FOR COLD EXTRUSION

**<sup>1</sup>I.A. OLA, <sup>2</sup>G.A. MAKANJUOLA, <sup>1</sup>E.S.A. AJISEGIRI, <sup>3</sup>O. AREMU AND  
<sup>1</sup>T.M.A. OLAYANJU**

<sup>1</sup>Department of Agricultural Engineering, Federal University of Agriculture, Abeokuta, Nigeria.

<sup>2</sup>Professor emeritus in the Department of Agricultural Engineering, Obafemi Awolowo University, Ile-Ife, Nigeria.

<sup>3</sup>Department of Engineering, Federal Institute of Industrial Research Oshodi (FIIRO), Lagos, Nigeria.

\*Corresponding author: kolainfo@yahoo.com      Tel: +2348033662968

---

### ABSTRACT

The timely production of diced dough for the final preparation of *chin-chin* (a confectionery made of fried dough) have not witnessed any substantial development among the women folk that engaged in such activities in Nigeria. A manually operated dough-dicing machine was designed and developed for the timely production of diced dough. The dough dicer offers a better method of dicing dough into various desired shapes and lengths, which may not be possible with the existing processing method. Preliminary test of the manually operated dough dicer showed that a minimal pressure of 4473.122 Pa is sufficient to force out the dough through the die outlet. The low cost dough dicer requires the minimum manual power input of 0.16 Watt for the dicing of the dough with a density of 1126.4 Kg/m<sup>3</sup>. The overall performance of the manually operated dough dicer showed that the machine would be of great benefit to the small scale producers of the confectionery.

**Key words:** Dough dicer, die outlet, cold extrusion, dicing, worm shaft

### INTRODUCTION

For a long time, the domestic mincing machine had remained an outstanding household or cottage machine used in the domestic preparation of dough before frying it into "*chin chin*". Most of the caterers in Nigeria still make use of the wooden boards with rollers for preparing the dough; and knives for dicing the dough. This method is rather cumbersome. The mixed dough must be flattened with the roller on the dough board before using a knife to slice and cut it

into the required shapes. Moreover, this method of processing exposes the dough to contaminations from contacts with the working surface. Some caterers even make use of objects like bottles and home-made wood as rollers. Apart from aforementioned disadvantage, this method of dough preparation is time consuming. Development of a manually operated dough-dicing for cold extrusion is inevitable since the existing method of dicing the dough entails the rolling of the dough into flat shapes before dicing. Al-

so the products are diced into longer lengths of dough and these might still be required to be diced into shorter lengths. Using the manually operated dough-dicing machine eliminates all these time consuming procedure.

Harper, (1979) reported that cold extrusion has being an important method used for the production of certain confectionery products such as pasta, hot-dogs, pastry dough and other confectionery. Cold extrusion entails the extrusion of products without pre-cooking it or distorting it as in the case of extrusion cooking. Extensive works have being done lately on food extrusion (Ranjit, and Subha, 2014; Bencomo, and Dominguez, 2000; van den Dungen, and Bergmans, 2000; Berry, 2000; Riaz *et al.*, 2007; Harper, 1979, Olkku *et al.*, 1980; Huber, 1984; Iwe *et al.*, 1997, Vincent, 1984; Slater, 1984). Fellows, 1988, explained that Extrusion is an example of a size enlargement process, in which smaller granular foods or powdered particles are reformed into larger pieces. In spite of the extensive work done in food extrusion lately, in other parts of world considerable proportion of dough based confectioneries produced in Nigeria are still done manually with a less appropriate processing method.

The existing method of producing longer length of diced dough entails the use of a manually operated roller to flatten the dough before cutting it. This cumbersome exercise makes such an activity less attractive to the women folk engaged in the production of "chin-chin". In fact, this has posed severe limitations to the commercial production of the product. Quite a lot of such prospective producers still make use of the old method of production; that is, flattening of the dough with a roller on the board

while making use of knives to finish the cutting of the dough into required sizes.

This paper describes the development of a less cumbersome low cost machine for the processing of dough before frying. The machine proffers a better solution to the problem encountered by small scale chin-chin producers. It also reduces the processing time it takes to produce the much desired length and shapes of diced dough. The operation of the developed dough dicer eliminates the customary flattening and cutting process associated with existing manual processing method. Moreover, this new method of processing is less rigorous. In addition, varied shapes and lengths of diced dough products can be produced on the machine.

## THEORY AND DESIGN PRINCIPLES

The basic principle of cold extrusion entails the extrusion of products at a minimal friction (Harper, 1979). The minimal extruding pressure (P) required to process the dough was determined using the relation stated below

$$P = \frac{F}{A} \quad (Pa) \quad \dots\dots\dots (1)$$

where, F is the minimum force required to cause the continuous plastic deformation of the dough in the barrel of the dicer.  
and, A is the area of the barrel of the dicer.

The minimum force (F) was determined indirectly by using standard weights to observe the flow characteristics of the dough in a piston-cylinder arrangement. The upper end of the cylinder shown in Fig.1 arbors the piston on which varied weights is placed. On the other extreme end of the cylinder is a

small orifice of precisely 6 mm diameter weight on plastic flow of dough can be observed through which the effects of the varied served.

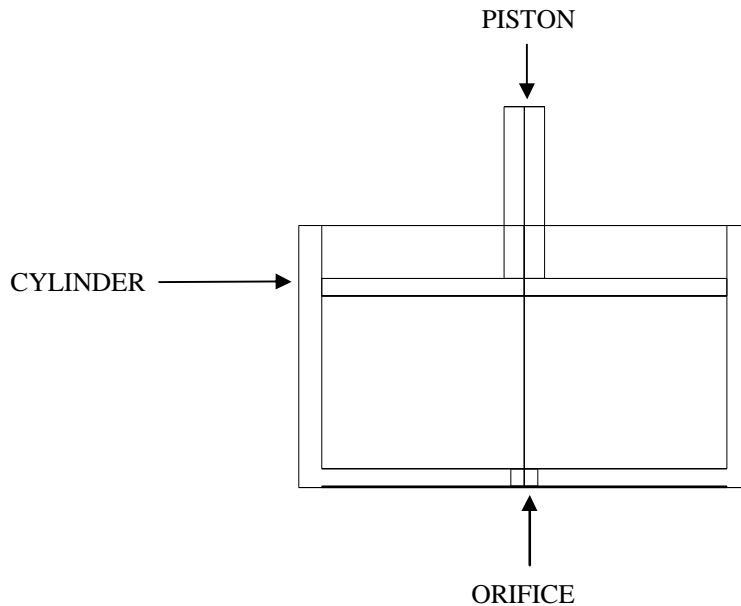

**Figure. 1: Piston and Cylinder Arrangement**

The mass flow rate ( $M_e$ ) of the dough through the dicer was monitored using a stopwatch as a known mass of dough was fed into the hopper of the machine. The following relation was used to determine the mass flow rate:

$$M_e = \frac{M}{t} (\text{Kg. sec}^{-1}) \dots\dots\dots (2)$$

where M is the total mass output of dough being processed at a given time t.

The density of the dough was also determined from the value of the mass and vol-

ume derived by water displacement method. The density (D) of the dough is given as:

$$M_e = \frac{M}{t} (\text{Kg. sec}^{-1}) \dots\dots\dots (3)$$

where  $V_s$  is the volume of equal of water displaced by the dough of mass ( $M_s$ ) inside a standard measuring cylinder. Multiplying equations (1) and (2) together and dividing this combination by equation (3) gives the minimum power ( $P_m$ ) required to turn the manual handle of the dicing machine.

That is;

$$P_m = \frac{\text{Pressure} \times \text{Mass flow rate}}{\text{Density}} (\text{Watt}) \dots\dots\dots (4)$$

$$P_m = \frac{F \times M_s}{D} (\text{Watt}) \dots\dots\dots (5)$$

$$P_m = \frac{F \times M_s \times V_s}{A \times M_s} (\text{Watt}) \dots\dots\dots (6)$$

The above equations were used in the design and the development of the dough-dicing machine. The essential component parts of the dough-dicing machine are the hopper, barrel, feed worm, dies, dicing blade, and the manual handle for turning the worm. The basic features of the components parts and the isometric view of the machine are shown in Fig 2 and Plate1 (a) and (b).

barrel through a hopper at the feed end of the barrel. The worm shaft conveys the dough to the discharged end of the barrel. The dough is forced out through the die outlet at the discharge end while a knife at the die end cuts the dough into small lengths. The diced dough prepared in this manner is now fried. Fig. 2 shows the schematic illustration of the dough-dicing machine developed for cold extrusion.

The machine operates as described briefly below. The kneaded dough is fed into the

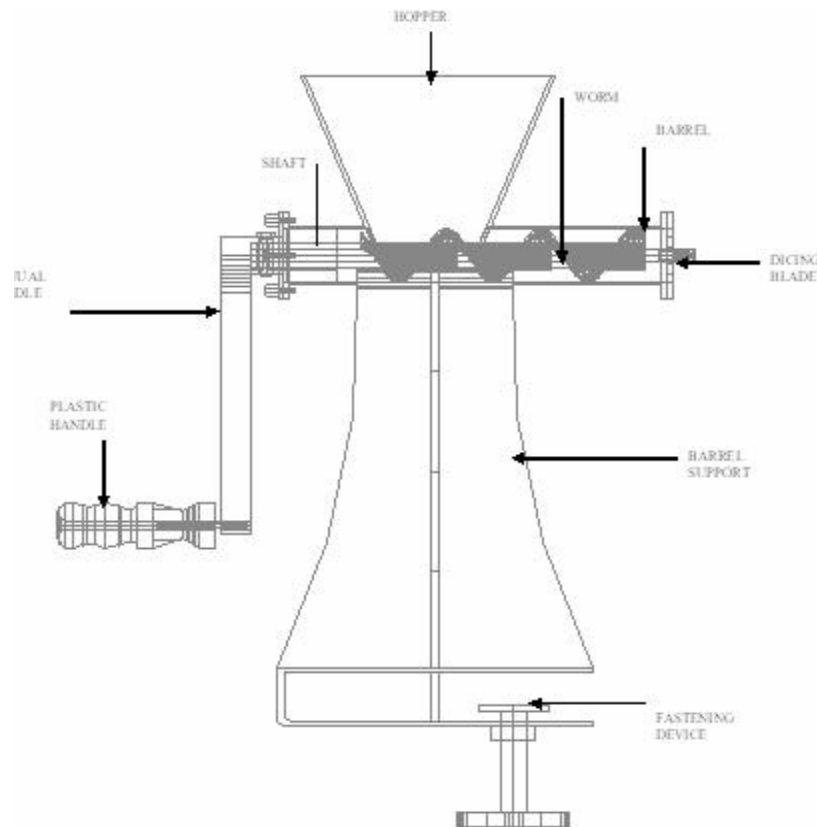

**Fig. 2: The schematic illustration of the dough-dicing machine developed for cold extrusion**



Plate 1 (a) Dough-dicing machine

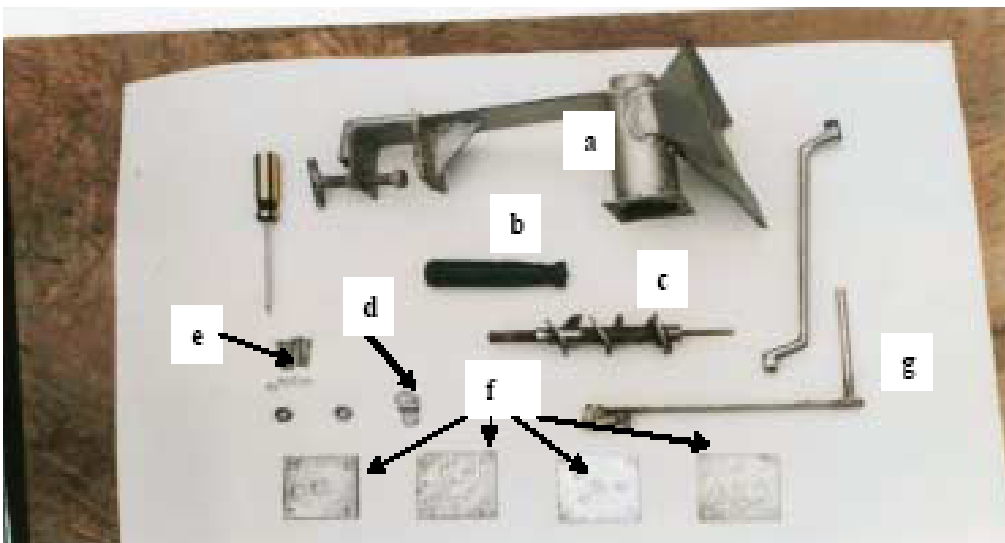

Plate 1(b) Component parts of dough-dicing machine: (a) hopper and feed barrel, (b) plastic handle, (c) worm shaft, (d) cutter, (e) bolts and nuts (f) die outlets, (g) manual handle.

## PRELIMINARY TESTING OF THE MANUAL DOUGH EXTRUDING MACHINE

### *Dough preparation*

Dough of density  $1126.41\text{kg/m}^3$  was prepared and divided into five equal parts. Each part weighed 200g. The first division of the dough was processed into the required shapes using the traditional method. The traditional method involves the use of a wooden roller, board and knives for manual cutting of the dough. The dough processed by this method is marked "M" as shown in Plate 2. The products marked 1, 2, 3, 4 in Plate 2 were dough extruded using the manually operated dough-dicing machine. The four categories of die plates shown in Plate 1 were being used for the extrusion respectively. The products marked 1, 2, 3, 4 Plate 2 were extruded from die having an outlets of 1, 2, 3, and 4

respectively. The processed dough was fried into the much-desired edible products "*chinchin*" shown in Plate 2. The time to complete the processing of each division of dough was monitored using a stopwatch. The results of the preliminary test of the operation of the dough-dicing machine is presented in the next section.

## RESULTS AND DISCUSSION

The time required to process kneaded dough into diced shapes was compared with that obtained from the traditional method and the result is presented in Table 1. The result showed that as the number of the extruding outlet increases the resident time of the dough increases which signifies that at highest number of outlets there was a reduction in flow or extrusion of the dough from the outlets. This fact is collaborated by similar work done by Ryu and Walker (1995).

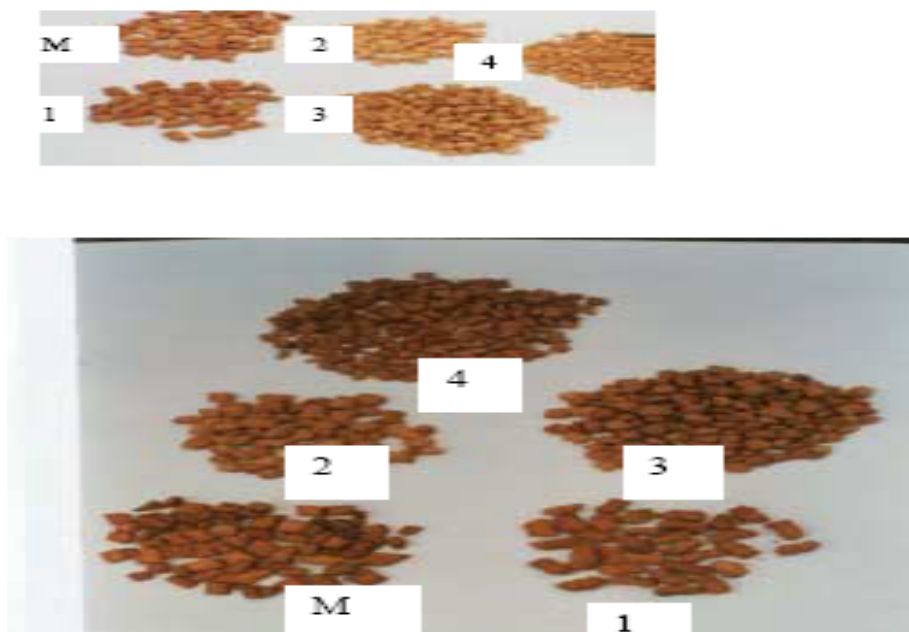
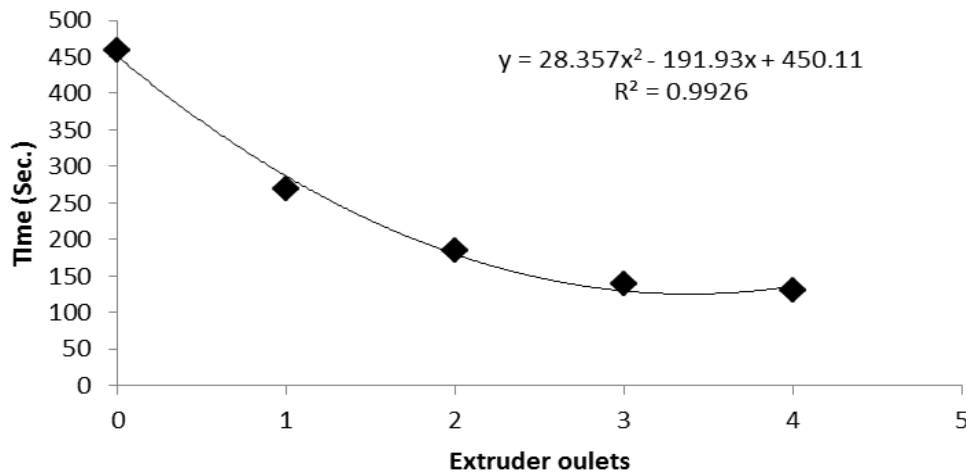

Plate 2 Products from the dough-dicer: (m) fried dough processed using the traditional method, (1) fried dough extruded through a single die outlet, (2) fried dough extruded through a dual die outlets, (3) fried dough extruded through a triple die outlets, (4) fried dough extruded through a quadruple die outlets.

**Table 1. Summary of the Rate of Processing Time in Dough Dicing Operation**

Processing Method	Number of Outlets On Die	Weight of Dough Extruded (g)	Processing Time (sec.)	Density (Kg/m <sup>3</sup> )	Estimated Pressure at Die Outlet (KPa)
Traditional	0	221.85	458	1126.41	-
Dough Dicer	1	221.85	269	1126.41	219.18
Dough Dicer	2	221.85	185	1126.41	219.18
Dough Dicer	3	221.85	140	1126.41	219.18
Dough Dicer	4	221.85	130	1126.41	219.18

**Fig. 3 Performance of dough dicing outlets in relation with time**

It can be observed (from Plate 2) that there were longer lengths of extruded dough obtainable with the single die outlet as compared to the other dies with 2, 3, and 4 outlets respectively. This also can be interpreted, as the number of die outlet increases there is definite reduction in flow rate of extruded dough hence the shorter the length of diced dough obtained. This preliminary result obtained showed that the manually operated

dough-dicing machine has a better processing advantage over the traditional method. The plot shown in Fig.3 showed that having more than four extrusion outlet might not bring improvement on the processing time, however, the best machine performance is when the outlets is four.

### CONCLUSION

A manually operated dough dicing had been developed. Preliminary tests showed that the

machine could be suited for dicing of dough. Thereby, it is of great benefit for local confectionery producers. This machine also has the capability of extruding various shapes and length of dough, which makes it more advantageous when compared to other domestic dough processing methods. This machine is also adaptable for fish farmers' blending fish meals into pellet forms.

### REFERENCES

- Bencomo, C.E., Dominguez, M.** 2000. Co-extrusion: a new method for the manufacture of bread. *Alimentaria*, **37** (310), pp 77-81.
- Berry, D.** 2000. New food solutions from extrusion. *Prepared Foods*, 169 (7), pp67-68, 70, 72.
- van den Dungen, W.J.E., Bergmans, P.J.C.M.** 2000. Apparatus for manufacturing co-extruded food products and method for manufacturing a coextruded food product. *PCT Patent Application*, patent number WO-00-44233.
- Harper, J.M.** 1979. Food Extrusion. CRC. Crit. Rev. Food. Sci. Nur., February 155-215
- Huber, G.R.** 1984. New extrusion technology for confectionery products. *Manuf. Confect.*, May, 51-52,54.
- Oikku, J., Hassinen, H., Antila, J., Pohjanpalo, H., Linko, P.** 1980. Automation of HTST-Extrusion cooker. In: P.Linko, Y. Malkki, J. Oikku and J. Larinkari (eds.), *Food Processing Engineering*, Vol. 1. Applied Science, London, pp 777-790.
- Slater, G.** 1984. Application of extrusion to the production of breakfast cereals. *Food. Trade Rev.* March 127-128.
- Vincent M. W.** 1984. Extruded confectionery - equipment and process. Vincet Processes Ltd, Shaw, Newbury, Berkshire, RG132NT, UK.
- Ranjit, B., Subha, G.** 2014. Extrusion technique in food processing and a review on its various technological parameters. *Ind. J. Sci. Res. and Tech.* 2(1):1-3/Bordoloi & Ganguly ISSN:-2321-9262 (Online) Online Available at: <http://www.indjsrt.com> Date accessed February 2<sup>nd</sup> 2015.
- Riaz, M.N., Anjum F.M., Khan M. I.** 2007 Latest trends in food processing using extrusion technology PAK. *J. FOOD SCI.*, 17(1), pp 53-138.
- Ryu G.H., Walker C.E.** 1995. The effect of extrusion conditions on the Physical Properties of wheat flour. *Extrudates. Starch/ Stärke* 47, Nr. 15. 33-36.

(Manuscript received: 1st December, 2014); accepted: 2nd March, 2015)