

DESIGN, CONSTRUCTION AND PRELIMINARY TESTING OF A BENISEED (*Sesamum indicum*) AIR-SCREEN CLEANER

*¹R. AKINOSO, ²T.M.A. OLAYANJU, ³L.O. HASSAN AND
³I.O. AJIBOSHIN

¹Department of Food Technology, Faculty of Technology, University of Ibadan, Ibadan, Nigeria.

²Department of Agricultural Engineering, College of Engineering, University of Agriculture Abeokuta, Abeokuta, Nigeria. E-mail: tiyanju@yahoo.com

³Federal Institute of Industrial Research (FIIRO), Blind Center Street, Cappa Oshodi Lagos, Nigeria.

*Corresponding author: akinoso2002@yahoo.com

ABSTRACT

A beniseed (*Sesamum indicum*) cleaner was designed and constructed based on the application of some determined physical and aerodynamic properties of the seed. The cleaner was an air-screen type with capacity of 200 kg/h. It consists of a set of vibratory screen made of steel mesh of different sizes. Top screen (2.0mm diameter) prevent foreign material bigger than beniseed while bottom screen (1.2mm diameter) retain beniseed and allow passage of material smaller than beniseed. A centrifugal fan with air speed of 2.5 m/s was incorporated to remove light materials. Preliminary testing of the machine with three varieties of beniseed showed that mean efficiency of separating good product from Yandev-55, E8 and Goza-25 were 66.80 ± 0.54 , 61.30 ± 0.85 and 80.08 ± 0.74 % respectively. In Addition, efficiency of separating bad products from Yandev-55, E8 and Goza-25 were 1.47 ± 0.41 , 1.61 ± 0.64 and 1.23 ± 0.47 % respectively. Total efficiency of the machine as determined were 98.2 ± 0.98 , 98.7 ± 1.24 and 98.5 ± 1.09 % for Yandev-55, E8 and Goza-25 varieties of beniseed respectively. At 95% confidence level, the machine efficiency is acceptable. Therefore, the machine is suitable for cleaning the three varieties of beniseed.

Keywords. Beniseed, air-screen, cleaner, terminal velocity, vibration

INTRODUCTION

Crops on harvest usually contain impurities which have to be removed for efficient and safe operation of processing equipment and production of good quality products. Examples of such impurities are unwanted seeds, plant residues, fungal impurities, rodent excreta, mud, dust and metal objects. These impurities reduce the value of the crop and

make it unfit for human consumption. Lucas and Olayanju (2003) stated that an average 50kg bag of beniseed (*Sesamum indicum*) in Nigeria markets contains average of 10% foreign materials which include; oversize materials like leaves, sticks and stems; undersize materials such sand and dust; same size material like hulls, empty shell of grains and stone. Beniseed that fail to meet interna-

tional standard are rejected for export (SON, 2000).

Cleaning is a prerequisite operation in food processing. It is the removal of unwanted materials. This operation need to be carefully performed since it is the last operation in the primary process line (Fellow and Hampton, 2003). Inefficiency in the operation reflects in final product. Therefore, any adopted method must be efficient and must not further damage the material. Traditionally, contaminants are removed by spreading the harvested crop in a thin layer on the threshing floor and the large contaminants mostly pieces of straw, are removed with rake. The remaining contaminant larger than the grains are removed with the broom or goose wings while light contaminants are removed by throwing the seed against the wind which lifted contaminant and ensure partial separation (Kacharu and Sahay, 1990). This manual process is usually time and energy consuming and the efficiency of separation is low. These factors led to the invention of mechanical cleaning devices whose operations consist almost solely of separating non edible impurities such as rubble, lumps, and stick straw and trapped irons from the seed. However, most of these machines are not effective cleaners for beniseed because of its small size. An improved method of cleaning that will meet consumers' needs and cost reduction is desirable. Development of an effective cleaner for varieties of beniseed in Nigeria was the focus of this work.

MATERIALS AND METHODS

Preliminary study

The first step was to survey numerous existing seed cleaners to identify both the features that are appropriate and those that should be modified in order to bring them

to the level of a small scale but efficient for processing of beniseeds. Some physical and aerodynamic parameters of three varieties of beniseed (Goza 25, Yandev 55 and E8) determined by Akinoso *et. al.*, 2008 and Olayanju *et. al.*, 2009 were utilized in the design of the machine. The properties were size, shape, density, coefficient of friction and terminal velocity.

Description of the machine

It consists of a hopper fitted above a screen box. The screen was made of a steel mesh of varied size. Top screen (2.0 mm diameter) prevent foreign material bigger than beniseed while bottom screen (1.2 mm diameter) retain beniseed and allow passage of material smaller than beniseed. Screen box was tilted at about 5 degrees to the horizontal and suspended by four tension springs and sitting on four compression springs which were oscillated by an eccentric unit. Next to the screen was a vertical separation column connected to a centrifugal fan. The fan was made of six plates attached to a bracket mounted on a shaft. It was driven by an electric motor (3.75 kW, 700 rpm), which also drives the screen box. Specification of the machine after fabrication is; length 1200 mm, width 1000 mm, height 1500 mm. Power transmission was by V belt and pulley arrangement. The orthographic and isometric views are as shown in Figure 1.

Design of vibratory screen

The machine mechanism was designed to enable angular motion to be converted to linear motion. Maximum force at the pin, torque output and power required to drive the machine were calculated using Equations 1 to 4.

$$\text{Power of Drive (W)} \quad P = T\omega \dots\dots 1$$

Torque Output (Nm) $T = Fr$2
 Force of Pin (N) $F = mg$3
 Angular velocity (rad/sec) $\omega = 2\pi N / 60$4

Where, N is angular speed = 240 rpm; m is total mass = 65 kg; r is radius of eccentric disc = 0.2 m; g is acceleration due to gravity = 9.8 m/s. Thus angular velocity $\omega = 25.12$ rad/sec, force $F = 637$ N, torque $T = 127.4$ Nm and power $P = 3200.26$ W. To give allowance for power use in driving the blower, a 3.75 kW electric motor rotating at a speed of 700 rpm was selected. Angular speed of 240 rpm required by eccentric disc to produce the screen vibration of 240 rpm was achieved by pulley ratio 1:3. Shear stress acting on driving pin was calculated using equation 5.

$$\sigma = 4F / \pi D^2$$
.....5

D is the diameter of the connecting rod = 0.02. $\sigma = 2.03$ N/mm². The grade stress of steel used as the material of construction is 40 N/mm², thus it is permissible.

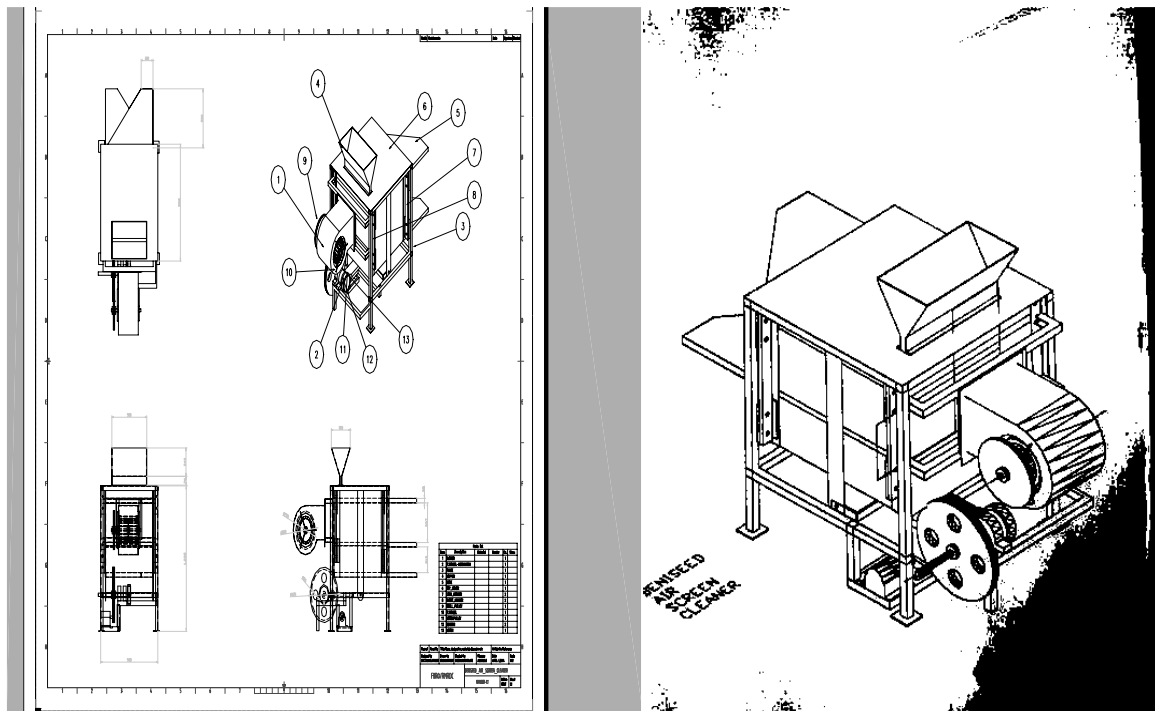

Figure 1: The orthographic and isometric views of the designed beniseed cleaner

Selection of helical spring

Compression and tension spring were selected from Kato-Entax Limited, Nottingham, England manufacturer chart. The selected spring was made of carbon and alloy steel and of 1,250 N/mm stresses capability.

Selection of fan

The fan must be capable of providing the required air velocity necessary for separation to take place. The efficiency of the fan is a function of terminal velocity. Inner radius of the housing is such as to span fan diameter adequately without friction and direct airflow through means of an exit which is to be attached to the air in let of the separator body. A centrifugal fan airfoil wheel model HDAF manufactured by Cincinnati Fan and Ventilator Company Inc. Ohio USA was selected. The desired air velocity of 2.5 m/s was achieved by belt driven arrangement as recommended by the manufacturer.

Performance evaluation

The machine capacity and cleaning efficiency were evaluated using method de-

scribe by Harmond *et. al.*, 1961. Three varieties of beniseed (Yandev-55, E8 & Goza-25) sourced from farms in Bida, Niger State was used as test materials. Samples of these varieties were taken to National Cereal Research Institute (NCRI) Badegi for classification. In determining the capacity, the designed and fabricated cleaner was fed continuously for 1h of operation using K-tron type T-35 volumetric feeder (K-tron Corp. Pitman, NJ U.S.A). Total weight of processed beniseed for the time duration was measured using Dvery weighing machine type-3205 COE 1250 kg (Avery Ltd, England). To ascertain cleaning efficiency, product from clean beniseed and contaminant discharge chute were separately collected and labeled as samples (Figure 2). Twenty samples each of known weight were prepared. Foreign materials in all the samples were manually separated. Efficiency of separating good product and bad reject were calculated using equations 6 & 7 respectively. Equation 8 gave total efficiency. Mean values of three replicates of the experiment were recorded as obtained data. These results were analysed statistically using ANOVA.

$$E_g = \frac{G P}{G P + G R} \times 100\% \dots\dots\dots 6$$

$$E_b = \frac{B R}{B R + B P} \times 100\% \dots\dots\dots 7$$

$$E_t = (E_g \cdot E_b) \times 100\% \dots\dots\dots 8$$

where

- E_g – Efficiency of separating good product
- E_b – Efficiency of separating bad reject
- E_t – Total efficiency
- G.P- Good product
- GR – Good reject
- BR – Bad reject
- BP – Bad product

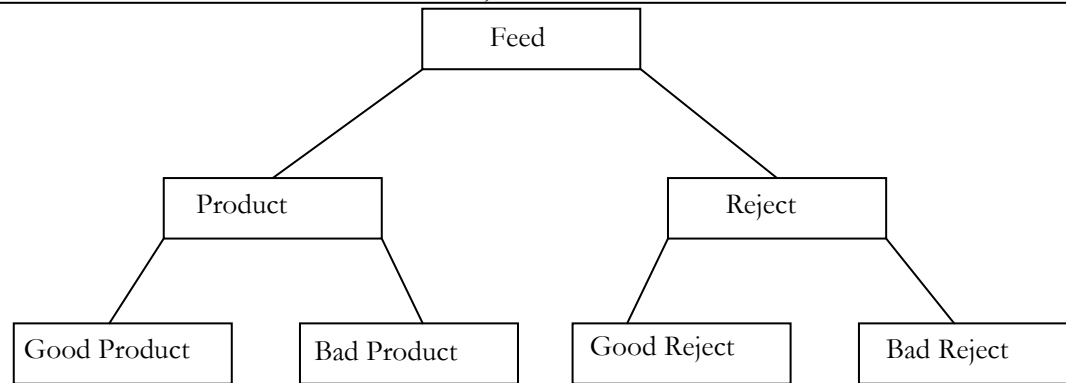

Figure 2. Diagram of separation classification during testing of cleaner

RESULTS AND DISCUSSION

From the survey it was observed that seeds can be cleaned based on differences between the desirable seed and contaminants. UNIFEM (1998) reported that the vibration screens separate products on the bases of difference in sizes of various constitute whereas air screen cleaners separate material on the basis of difference in size and weight. The report further stated that the seed having different in lengths are separated by disc and indented cylinder while materials with different shape are separated in spiral separator. The predetermined physical and aerodynamic properties of beniseed was shown as Table 1. Based on these parameters, input capacity, top and bottom sizes were 200 kg/h, 2.0 and 1.2 mm respectively. For simplicity of design, the following assumptions were made; a simple separating machine uses only one differentiating characteristics. The grains are assumed to be spheroid. The differences in the behaviour of seeds are caused by the difference in aerodynamics properties. At low Reynolds number, the inertia of the displaced air is negligible and the drag is due to viscous shear alone. In order to remove contaminants from beniseed a sieving machine which incorporates an air blower is

considered for the separation of oversize and undersize materials as well as the removal of light hulls and empty shells.

Testing

The result obtained after using the design and fabricated cleaner (Figure 3) to clean three varieties of beniseed separately is shown in Table 2. Capacity of the machine was determined to be 215 kg/h and it can be approximated to 2 tons/day of 8 working hours, considering time that may be lost due to manual feeding. No significant variation at $p \leq 0.05$ was recorded among the capacities of three different varieties of beniseed used for the test. The mean efficiency of separating good product from Yandev-55, E8 and Goza-25 were 66.80 ± 0.54 , 61.30 ± 0.85 and 80.08 ± 0.74 % respectively. In addition, efficiency of separating bad products from Yandev-55, E8, and Goza-25 were 1.47 ± 0.41 , 1.61 ± 0.64 and 1.23 ± 0.47 % respectively. The exportable quality grade and standard for beniseed as recommended by International Commodities Board is 2 % by weight of contaminant (Hockman, 1998). Thus the machine performance as reflected in the experimental result show that the machine can be used to process harvested beniseed that will satisfy the exportable quality

standard for beniseed. Variation recorded in the results of the three varieties may be traced to slight differences in their sizes and shape (Table 1). Similar observation was reported by Igbeka (1984). Total efficiency

of the machine as determined were 98.2 ± 0.98 , 98.7 ± 1.24 and 98.5 ± 1.09 % for Yandev-55, E8 and Goza-25 varieties of beniseed respectively. All these are acceptable at $p \leq 0.05$.

Table 1: Some physical properties of beniseed accessions factored in the design

Properties	Goza 25	Yandev 55	E8	Mean value
Major diameter, mm	2.21	2.8	3.3	2.77
Intermediate diameter, mm	1.54	1.83	2.13	1.73
Minor diameter, mm	0.36	0.68	0.75	0.6
Geometric mean, mm	0.99	1.52	1.74	1.42
Sphericity	0.45	0.54	0.54	0.51
Bulk density, kg/m ²	721	688	674	694
True density, kg/m ³	998	1042	1050	1030
Porosity, %	27.76	33.97	35.81	32.51
Thousand kernel wt., g	2.13	2.63	2.98	2.58
Coeff. of friction on M/S	0.58	0.51	0.14	0.5
Terminal velocity, m/s	3.92	3.05	2.79	3.25



Figure 3: Front view of the fabricated air-screen cleaner

Table 2: Performance evaluation of the machine using three varieties of beniseed

Samples	Yandev-55			E8			Goza-25		
	E _g (%)	E _b (%)	E _t (%)	E _g (%)	E _b (%)	E _t (%)	E _g (%)	E _b (%)	E _t (%)
A	89.2	1.1 ± 0.2	98.2±1.4	61.2	1.6 ± 0.2	97.9±0.9	90.2	1.1 ± 0.5	99.2±0.5
B	51.5	1.9 ± 0.9	97.9±2.6	57.6	1.7 ± 1.4	98.0±0.3	58.5	0.7 ± 0.1	99.4±3.1
C	57.3	1.7 ± 0.5	97.4±3.1	49.1	2.0 ± 0.5	98.1±0.4	57.0	1.7 ± 1.1	96.9±0.6
D	60.9	1.6 ± 0.3	97.5±1.4	51.5	0.9 ± 0.2	97.9±1.2	49.4	2.0 ± 1.7	98.8±1.7
E	49.2	2.0 ± 1.2	98.3±1.7	33.4	2.9 ± 0.5	97.0±0.7	99.0	1.0 ± 1.3	99.0±2.1
F	64.8	1.5 ± 0.8	97.2±2.8	65.3	1.5 ± 0.8	97.9±0.8	46.7	2.1 ± 1.8	98.0±0.4
G	70.3	1.4 ± 0.6	98.5±1.9	70.5	0.4 ± 0.1	98.7±2.4	51.5	0.9 ± 1.1	97.9±0.7
H	51.6	1.9 ± 1.4	98.1±1.1	60.2	1.6 ± 0.6	96.3±4.0	61.3	0.6 ± 0.4	98.1±1.9
I	70.9	0.4 ± 0.2	99.3±2.6	70.7	1.4 ± 0.2	99.0±1.3	75.5	0.3 ± 0.1	98.1±1.9
J	42.8	2.3 ± 1.5	98.5±1.4	49.3	2.0 ± 1.7	98.5±0.9	89.0	1.1 ± 1.0	97.9±3.4
K	58.0	0.7 ± 0.1	98.6±2.3	42.6	2.3 ± 0.3	98.1±0.9	82.5	1.2 ± 1.1	99.0±1.7
L	46.7	2.1 ± 1.2	98.0±3.1	43.8	2.2 ± 2.1	96.3±2.1	81.7	1.2 ± 1.1	98.0±0.1
M	46.8	2.1 ± 1.2	98.3±0.6	49.4	2.0 ± 1.5	98.7±3.9	66.2	1.5 ± 1.1	99.3±1.1
N	76.1	1.3 ± 0.3	98.9±2.9	64.2	1.5 ± 1.1	96.3±2.1	61.7	1.6 ± 1.1	98.7±2.6
O	89.2	1.1 ± 0.1	98.1±1.1	65.8	0.5 ± 0.1	98.7±1.1	70.4	1.4 ± 0.4	98.6±1.8
P	70.5	1.4 ± 0.5	98.7±2.3	49.6	2.0 ± 0.1	99.1±0.6	57.8	1.7 ± 0.6	98.3±3.1
Q	51.6	1.9 ± 1.7	98.0±1.2	64.7	1.5 ± 1.2	97.0±2.3	80.8	1.2 ± 0.3	97.0±0.6
R	70.1	1.4 ± 0.8	98.2±2.1	70.6	1.4 ± 1.2	98.8±4.2	99.5	1.0 ± 0.1	99.5±1.4
S	66.1	0.5 ± 0.1	99.1±2.1	46.9	2.1 ± 1.4	98.6±1.1	82.0	0.7 ± 0.1	98.4±2.2
T	89.1	1.1 ± 0.1	98.0±1.6	61.3	1.6 ± 1.1	98.0±0.7	66.0	1.5 ± 0.9	99.0±2.3

E_g - Efficiency of separating good product; E_b – Efficiency of separating bad reject; E_t–Total efficiency

CONCLUSION

A cottage level seed cleaning machine was designed, fabricated and tested. The machine was found suitable for cleaning three varieties of beniseed. Using this air-screen cleaner, difference in total efficiency of cleaning the three varieties (Yandev-55, E8 and Goza-25) of beniseed was not significant at $p \leq 0.05$. The design concept of the cleaner can be adopted for development of cottage cleaner suitable for other crops such as rice, beans, cowpea and soybean. Commercial production of the machine will bring succour to peasant beniseed farmers.

REFERENCES

- Akinoso, R., Igbeka, J.C., Olayanju, T.M.A.** 2006. Process optimization of oil expression from sesame seed (*Sesamum indicum*). *CIGR Ejournal*. Man FP 06 011: 8
- Akinoso, R., Olayanju, T.M.A, Idehai, A.O., Igbeka, J.C.** 2008. Effect of Varieties and Moisture Content on Some Physical and Aerodynamic Properties of Sesame Seed (*Sesamum indicum* L) as Related to Cleaning. *International Journal of Food Engineering*, 4(8): 10.

- Fellow, P., Hampton, A.** 2003. Small scale food processing. A guide to appropriate equipment intermediate technology. *FAO Publication* 2nd edition, Netherlands.
- Harmond, J.E, Leonard, M.K., Brandenburg, N.R.** 1961. Seed cleaning and handling agricultural research service, *USDA Agriculture Handbook* No. 179, Washington, DC.
- Hockman, M.** 1998. Processing, marketing and uses of by-products of sesame seed. *African Sesame Seed Forum* Lagos, Nigeria. 37pp.
- Igbeka, J.C.** 1984. An appropriate technology cereal cleaner. *Journal of Agricultural Mechanization in Asia, Africa and Latin America (AMA)*, 15: 67-70.
- Kachru, R., Sahay, K.M.** 1990. Development and testing of pedal cum power operated air-screen grain cleaner. *Journal of Agricultural Mechanization in Asia, Africa and Latin America (AMA)*, 21: 29-32.
- Lucas, E.B., Olayanju, T.M.A.** 2003. Effects of moisture content on some physical properties of two accessions of beniseed. *Journal of Applied Science and Technology*, 3: 7-12.
- Olayanju, T.M.A, Akinoso R., Aderinlewo, A.A., Dairo, O.U., Ola, I.A.,** 2009. Moisture Dependence of Some Aerodynamics Properties of Beniseed. *ASSET – An International Journal*. Series B 8(1): 68-76.
- SON,** 2000. Nigeria Industrial Standard. Standard for Edible Vegetable Oil NIS: 388: 2000. *Standard Organization of Nigeria*
- UNIFEM,** 1988. Cereal processing, food cycle and technology source book three. *The United Nation Development Fund for Women*, New York

(Manuscript received: 4th September, 2010; accepted: 11th April, 2011).